

THIS DRAWING IS UNPUBLISHED. RELEASED FOR PUBLICATION, 19 .
 © COPYRIGHT 19 BY AMP INCORPORATED. ALL INTERNATIONAL RIGHTS RESERVED.

| LOC | | DIST | | REVISIONS | | | | DATE | APPD |
|-----|----|------|-----|-------------|--------------------------------|--|--------|---------|------|
| P | F | ZONE | LTR | DESCRIPTION | | | | | |
| G | 14 | | | B | REV & REDRAWN PER 0720-0040-93 | | 4-8-93 | APP DAP | |

METRIC
 DIMENSIONS LISTED IN mm [INCHES]

| | |
|-------------------------------|----------------------------|
| AMP WIRE RANGE | UL E13288 Listed |
| 2/0 AWG SOLID OR STRANDED | 2/0 AWG STRANDED |
| SR LR7189 Certified | MILITARY P/N AND CLASS |
| 2/0 AWG SOLID OR STRANDED | NOT APPLICABLE |

① STAMP AMP 2/0W* APPROX AS SHOWN

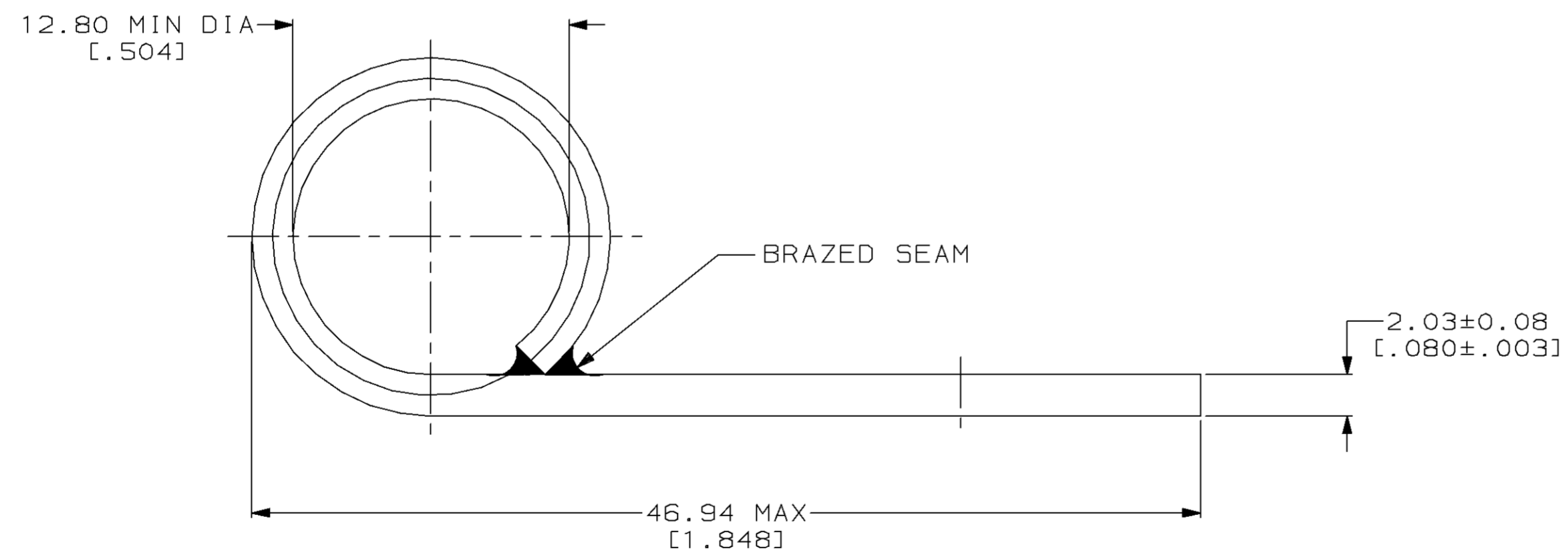
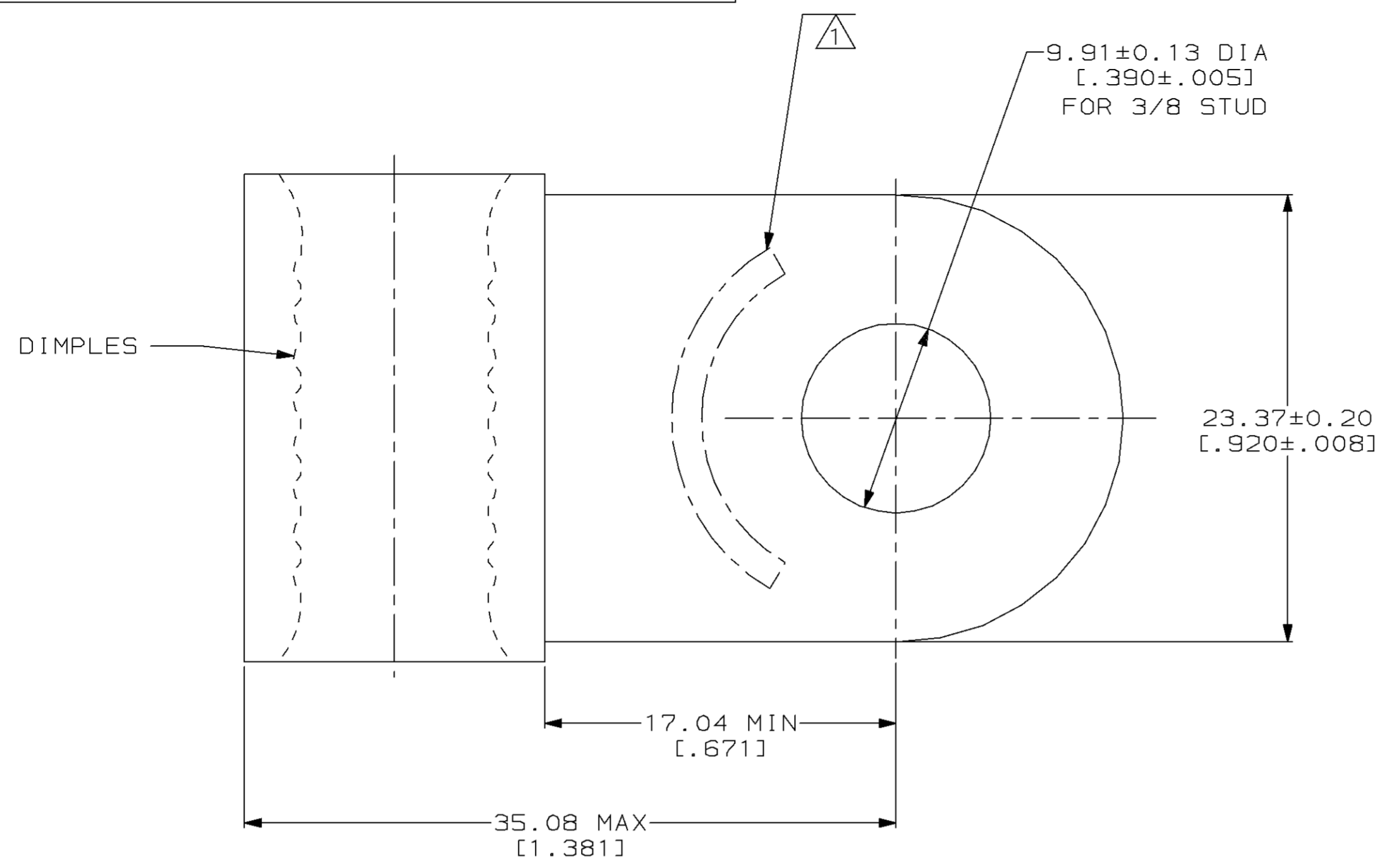

| | | | | | | |
|--|--|---|--|----------------------------|---|------------------------|
| AMP INCORPORATED CUSTOMER SERVICE SYSTEMS | | MAX RECOMMENDED OPERATING TEMPERATURE: 170°C MAX | DO NOT SCALE PRINT. UNLESS SPECIFIED DIMENSIONS IN mm [INCHES] TOLERANCES ON: 2 PLC DEC ± - 3 PLC DEC ± - ANGLES ± - | DR 4-8-93 TA BRINKMAN | 321584 PART NO | |
| FOR ADDITIONAL PRODUCT INFORMATION OR COPIES OF DRAWINGS AND TECHNICAL DOCUMENTS | PRODUCT INFORMATION CENTER 1-800-522-6752 | VOLTAGE RATING: NOT APPLICABLE | MATERIAL COPPER PER ASTM B-152 ANNEALED | CHK 4-8-93 DA PATTERSON | AMP AMP Incorporated Harrisburg, PA 17105-3608 | |
| FOR APPLICATION TOOLING INFORMATION | TOOLING ASSISTANCE CENTER 1-800-722-1111 | WIRE CROSS SECTIONAL AREA RANGE: 60.6-76.3mm² [119,500-150,500] CIR MILS SOLID OR STRANDED | FINISH TIN PLATE 0.00254[.000100] MIN THK PER MIL-T-10727 | APPD 4-8-93 DE MILLER | NAME TERMINAL, RING TONGUE, FLAG, SOLISTRAND™ | |
| FOR ORDER ENTRY | 1-800-526-5142 | THIS DRAWING IS A CONTROLLED DOCUMENT FOR AMP INCORPORATED. IT IS SUBJECT TO CHANGE AND THE CONTROLLING ENGINEERING ORGANIZATION SHOULD BE CONTACTED FOR THE LATEST REVISION. | | APPD 4-8-93 JL MECKLEY | SIZE ③ 00779 | DRAWING NO ③=321584 |
| AMP 1471-6 REV 3-92 | | | | PRODUCT SPEC - | SCALE 4:1 | SHEET 1 OF 1 |

CUSTOMER DRAWING